

Flaring Tools

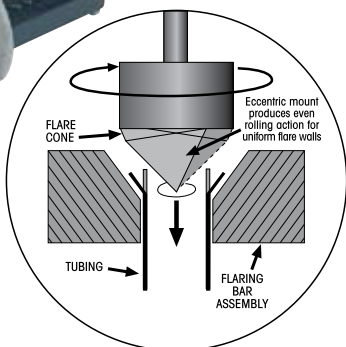

No. 458R Ratchet Flaring Tool

- This precision tool provides smooth, uniform flares with minimum effort.
- The new ratcheting feed screw handle turns easily and requires less motion and effort than a standard handle.
- Hardened steel flaring cone, eccentrically mounted in needle bearings, produces rolling action for even metal flow, giving uniform flare walls without galling.

Catalog No.	Model No.	Description	Sizes (in.)	Weight		Std. Pack
				lb.	kg	
83037	458R	45° SAE Flares	1/8, 3/16, 1/4, 5/16, 3/8, 1/2, 5/8, 3/4	3 1/2	1.6	1
41295	454-W	45° SAE-Nominal Water Tube	3/8, 1/2, 3/4, 1	6 1/4	2.8	1
41300	455	45° SAE Flares	1/2, 5/8, 3/4, 7/8, 1	6 3/4	3.1	1
41162	377	37° SAE Flares	3/16, 1/4, 5/16, 3/8, 1/2, 5/8, 3/4	3 1/2	1.6	1
41285	375	37° SAE Flares	1/2, 5/8, 3/4, 7/8, 1	6 3/4	3.1	1
Metric Model			Sizes (mm)			
50257	458MM	45° SAE Flares	4, 4.75, 6, 8, 10, 12, 15, 16	3 1/2	1.6	1

All flaring tools listed are recommended for soft materials such as aluminum and soft copper. No. 454W, No. 455 and No. 375 will also flare steel, stainless steel, hard copper and brass. No. 458R, No. 458MM and No. 377 will flare steel, stainless steel, hard copper, and brass thru wall thickness of .035 inches.

No. 345 Flaring Tool

- Model 345 is a precision designed tool for producing 45° flares in soft copper, brass, aluminum and mild steel (JIC and Bundy) tubing.
- A hardened, smooth cone provides fast, 45° flares either single or double lap.
- A single clamp screw provides for easy clamping and removal of tubing.



Catalog No.	Model No.	Description	Sizes (in.)	Weight		Std. Pack
				lb.	kg	
23332	345	45° SAE Flares	3/16", 1/4", 5/16", 3/8", 7/16", 1/2", 5/8"	2 3/4	1.2	1
23337	345-DL	45° SAE-(double flares)	Above w/adapters for double lap flares; 3/16", 1/4", 5/16", 3/8", 7/16", 1/2" O.D. Tubing	3	1.3	1
24797	345/150	45° SAE Flares	No. 345 w/No. 150 Tubing Cutter and Case Kit	3 1/2	1.6	1
33927	345/150DL	45° SAE Flares	No. 345/DL w/No. 150 Tubing Cutter and Case Kit	3 1/2	1.6	1
31597	-	-	3/16" Double Lap Adapter	-	-	-
31602	-	-	1/4" Double Lap Adapter	-	-	-
31607	-	-	5/16" Double Lap Adapter	-	-	-
31612	-	-	3/8" Double Lap Adapter	-	-	-
31617	-	-	1/2" Double Lap Adapter	-	-	-
Metric Model			Sizes (mm)			
23342	345M	45° SAE Flares	6, 8, 10, 12, 14, 15, and 16	2 3/4	1.2	1
24087	345M/150	45° SAE Flares	No. 345M w/No. 150 Tubing Cutter and Case Kit	3 1/2	1.6	1
31502	-	-	Case Only	-	-	-

Hammer-Type Flaring Tools

- Made of high-grade, hardened steel, these tools have a long nose guide that centers tools for smooth, 45° uniform flares.



Catalog No.	Model No.	Water Tube Size		Weight		Std. Pack
		in.	mm	lb.	kg	
41315	E-37	3/8	9	3/16	0.1	1
41320	E-45	1/2	12	1/4	0.1	1
41325	E-46	5/8	16	3/8	0.2	1
41330	E-47	3/4	19	1/2	0.2	1
41335	E-52	1	25	3/4	0.3	1
41340	E-61	1 1/4	31	1	0.5	1
41345	E-63	1 1/2	37	1 1/2	0.7	1
41350	E-64	2	50	2 1/2	1.0	1